

TC Series

Touch Switch Type Temperature Controller

■ Features

- Realizes ideal temp. controlling with newly developed PID control algorithm and 100ms high speed sampling
- Relay output and SSRP output embodied together : SSRP output makes phase control and cycle control possible.
- Dramatically increased visibility using wide display part
- Mounting space saving with compact design : Approx. 38% reduced size compared with existing model(depth-based)
- Deviation between SV and PV indicatable



⚠ Please read "Caution for your safety" in operation manual before using.

■ Ordering information

T	C	4	S	—	1	4	R
Item	Setting type	Digit	Size		Size	Power supply	Control output
	C	4	S		1	4	N
	Set by touch switch	4Digit	DIN W48×H48mm(Terminal block type)		Alarm1 output	100-240VAC 50/60Hz	Indicator - Without control output
	T		SP		2		R
	Temperature controller		DIN W48×H48mm(Plug type)		Alarm1 output+Alarm2 output		Relay output+SSR output
			Y	(※1)			
			DIN W72×H36mm				
			M	(※2)			
			DIN W72×H72mm				
			H				
			DIN W48×H96mm				
			W				
			DIN W96×H48mm				
			L				
			DIN W96×H96mm				

(※1) It is unavailable for TC4SP, TC4Y.

(※2) TC4SP sockets (PG-11, PS-11) are sold separately.

■ Specifications

Series	TC4S	TC4SP	TC4Y	TC4M	TC4H	TC4W	TC4L	
Power supply	100-240VAC 50/60Hz							
Allowable voltage range	90~110% of rated voltage							
Power consumption	Max. 5VA							
Display method	7Segment (Red), Other display (Green, Yellow, Red LED)							
Character size	W7×H15mm	W7.4×H15mm	W9.5×H20mm	W7×H14.6mm	W9.5×H20mm	W11×H22mm		
Input type	RTD	DIN Pt100Ω (Allowable line resistance max.5Ω per a wire)						
	TC	K(CA), J(IC)						
Display method	TC, RTD	(★1) (PV ±0.5% or ±1℃ higher one) rdg ±1Digit					(★2) *TC4SP (Plug type) is (PV ±0.5% or ±2℃ higher one) rdg ±1Digit	
		☞Based on normal temperature (23℃ ±5℃)						
Control output	Relay	250VAC 3A 1a						
	SSR	12VDC ±2V 20mA Max.						
Sub output	AL1, AL2 relay output : 250VAC 1A 1a(※TC4SP, TC4Y have AL1 only.)							
Control method	ON/OFF and P, PI, PD, PID control							

* (★1) (PV ±0.5% or ±2℃ higher one) rdg ±1Digit, except normal temperature range.

* (★2) TC4SP is (PV ±0.5% or ±3℃ higher one) rdg ±1Digit, except normal temperature range.

Touch Switch Type Temperature Controller

Specifications

Series	TC4S	TC4SP	TC4Y	TC4M	TC4H	TC4W	TC4L
Control method	ON/OFF and P, PI, PD, PID control						
Hysteresis	1 ~ 100°C (KCA, JIC, PT1) / 0.1 ~ 50.0°C (PT2)						
Proportional band	0.1 ~ 999.9°C						
Integral time (I)	9999sec.						
Derivative time (D)	9999sec.						
Control period	0.5 ~ 120.0sec.						
Manual reset	0.0 ~ 100.0%						
Sampling period	100ms						
Dielectric strength	2000VAC 50/60Hz for 1min. (Between input terminal and power terminal)						
Vibration	0.75mm amplitude at frequency of 5~55Hz in each X, Y, Z directions for 2 hours						
Relay life cycle	Mechanical	Min. 10,000,000 operations					
	Malfunction	Min. 100,000 operations (at 250VAC 3A resistive load)					
Insulation resistance	Min. 100MΩ (at 500VDC mega)						
Noise	Square shaped noise by noise simulator (pulse width 1μs) ±2kV R-phase and S-phase						
Memory retention	Approx. 10 years (When using non-volatile semiconductor memory type)						
Ambient temperature	-10 ~ 50°C (at non-freezing status)						
Storage temperature	-20 ~ 60°C (at non-freezing status)						
Ambient humidity	35 ~ 85%RH						
Unit weight	Approx. 97g	Approx. 84g	Approx. 127g	Approx. 127g	Approx. 118g	Approx. 118g	Approx. 172g
Approval							

Connections

※TC4 series has both Main Out and SSR Out. You may select the model as your needs.

TC4S

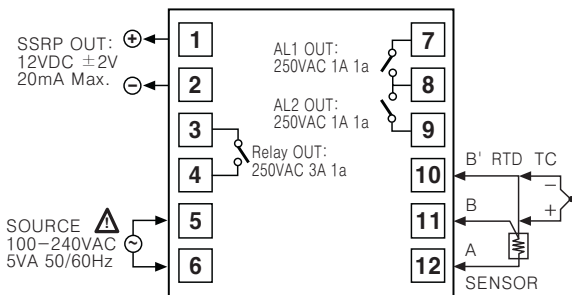

TC4SP

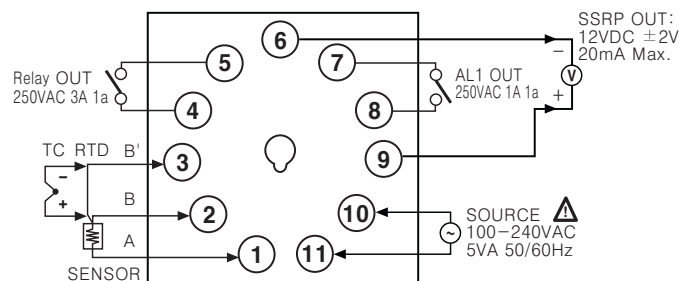

TC4Y

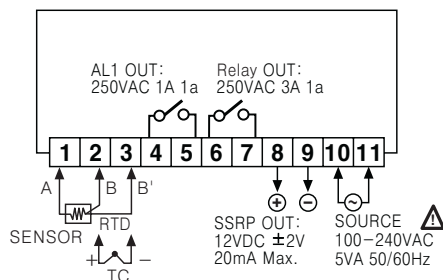

TC4W

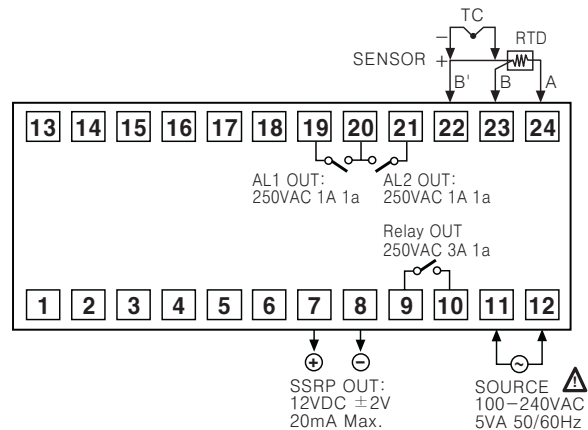

(A) Counter

(B) Timer

(C) Temp. controller

(D) Power controller

(E) Panel meter

(F) Tacho/Speed/Pulse meter

(G) Display unit

(H) Sensor controller

(I) Switching power supply

(J) Proximity sensor

(K) Photo electric sensor

(L) Pressure sensor

(M) Rotary encoder

(N) Stepping motor & Driver & Controller

(O) Graphic panel

(P) Production stoppage models & replacement

TC Series

●TC4M

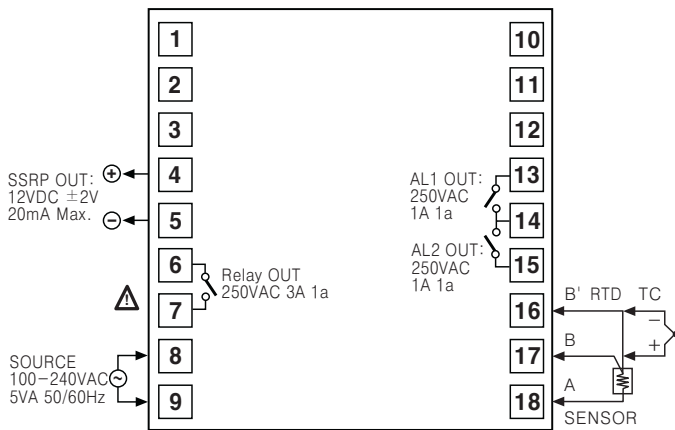

●TC4H/L

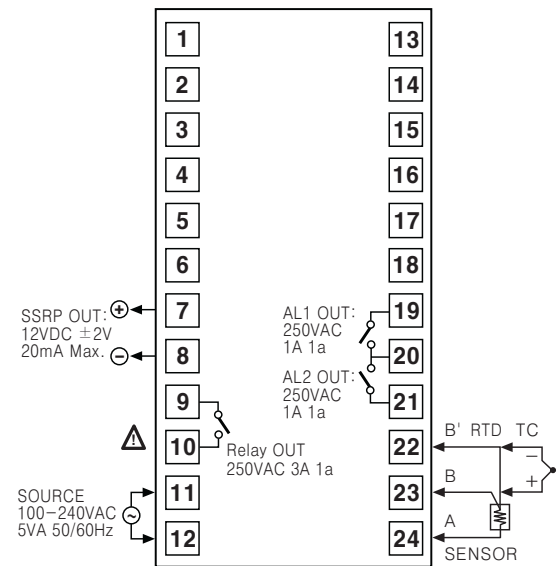

■Dimensions

●TC4S

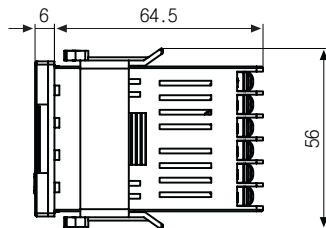
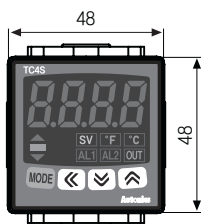

●Panel cut-out

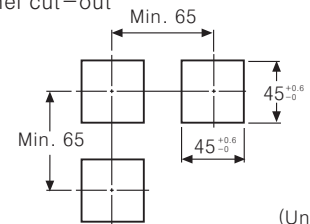

(Unit:mm)

●TC4SP

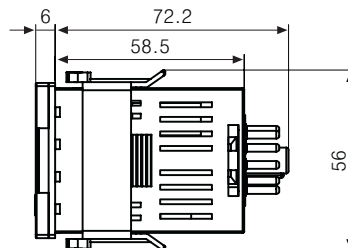
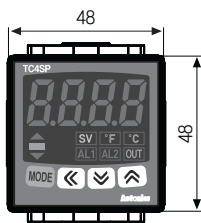

●Panel cut-out

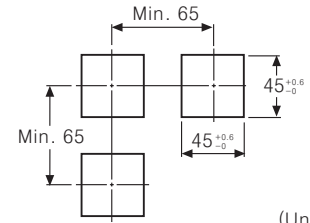

(Unit:mm)

●TC4Y

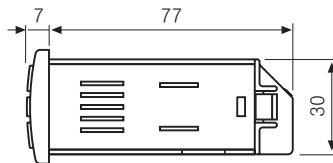
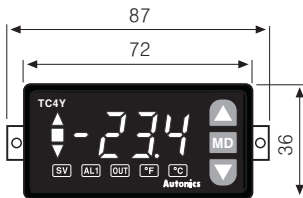

●Panel cut-out

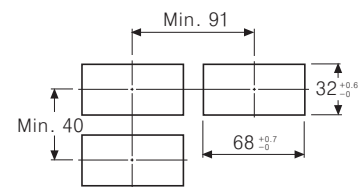

(Unit:mm)

●TC4M

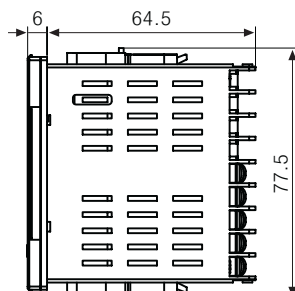
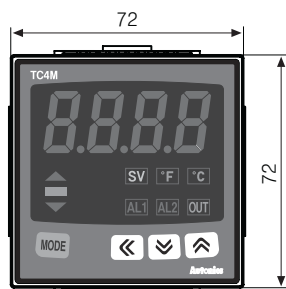

●Panel cut-out

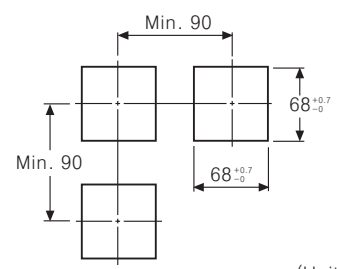

(Unit:mm)

Touch Switch Type Temperature Controller

●TC4H

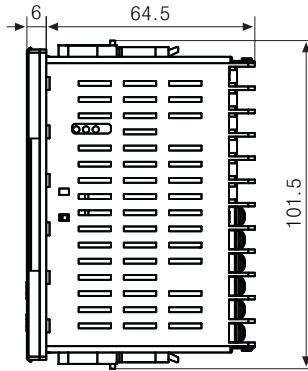
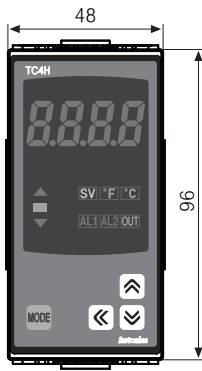

●Panel cut-out

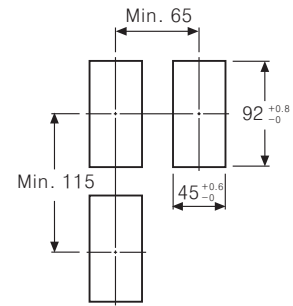

(Unit:mm)

●TC4W

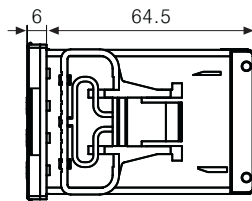

●Panel cut-out

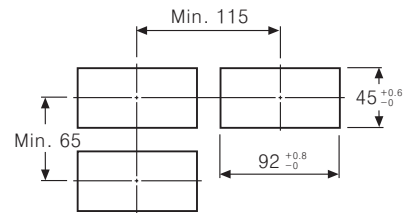

(Unit:mm)

●TC4L

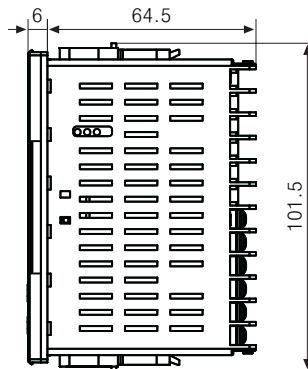

●Panel cut-out

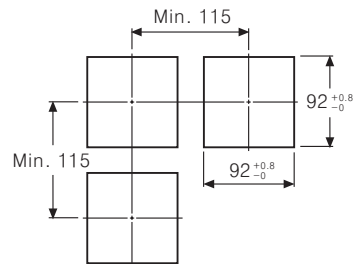

(Unit:mm)

■ Product mounting

●TC4S/SP(48×48mm) series

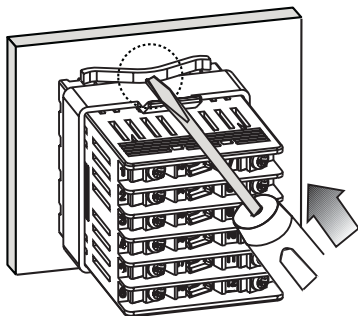

●TC4Y(72×36mm) series

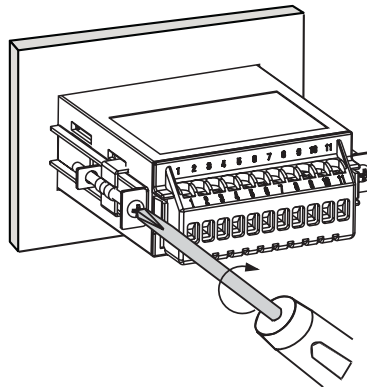

●Other series

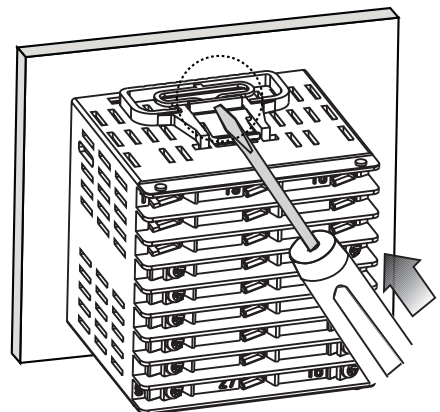

※ Insert product into a panel, fasten bracket by pushing with tools as shown above.
(In case of TC4Y, fasten the bracket bolts.)

(A) Counter

(B) Timer

(C) Temp. controller

(D) Power controller

(E) Panel meter

(F) Tacho/Speed/Pulse meter

(G) Display unit

(H) Sensor controller

(I) Switching power supply

(J) Proximity sensor

(K) Photo electric sensor

(L) Pressure sensor

(M) Rotary encoder

(N) Stepping motor & Driver & Controller

(O) Graphic panel

(P) Production stoppage models & replacement

TC Series

■SSRP(Solid State Relay Phase Output) output function[55r.n]

- SSRP is a user selectable output type which phase control and cycle control are added to standard SSR output.
- Standard SSR output is still available by internal parameter setting [55r.n]; in addition, "cycle control" with connecting Zero cross turn-on type SSR and "phase control" with connecting Random turn-on type SSR are also available.
- Realizing high accuracy and cost effective temperature control with both current output(4-20mA) and linear output(cycle control and phase control).

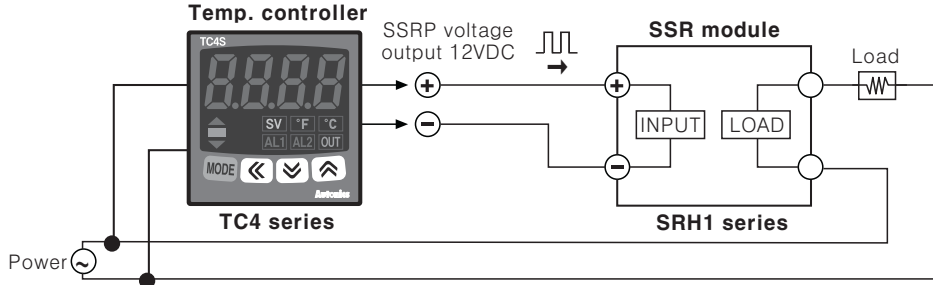

※You can select the functions with parameter settings.

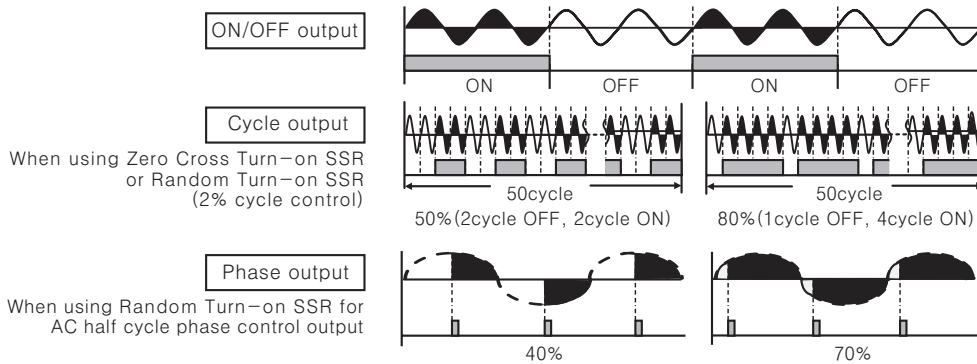

- Standard control mode[5tnd]
 - A mode to control the load in the same way as RELAY output type.(ON: output level 100%, OFF: output level 0%)
- Cycle control mode[CYCL]
 - A mode to control the load by repeating output ON / OFF according to the rate of output within setting cycle
 - Having improved ON / OFF noise feature(ZERO CROSS type)
- Phase control mode[PHAS]
 - A mode to control the load by controlling the phase within AC half cycle.
 - Serial control is available
 - RANDOM Turn-on type SSR must be used for this mode.

※When selecting phase or cycle control mode, the power supply for load and temperature controller must be the same.
 ※In case of selecting PID control type and phase / cycle control output modes, control cycle (t) is not allowed to set.

■Parts description

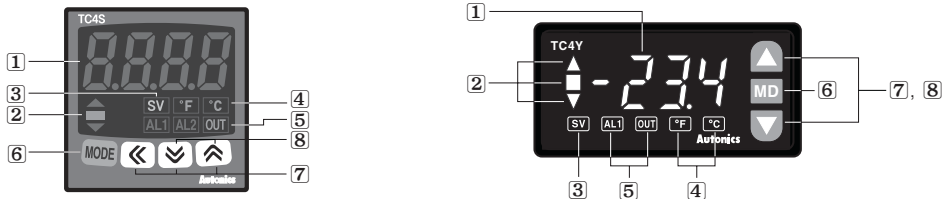

- Temperature display
 - It shows current temperature (PV) in RUN mode and parameter and set value for each setting group in parameter change mode.
- Deviation and Auto-tuning indicator
 - It shows current temperature (PV) based on set temperature (SV) by LED.
 - Deviation indicators (▲, ■, ▼) are flashed by every 1sec when operating auto-tuning.
- Set temperature (SV) indicator
 - Press any front key once to check or change current set temperature (SV), set temperature (SV) indicator is on and preset set value is flashed.
- Temperature (°C/°F) indicator : It shows current temperature unit.
- Control/sub output indicator
 - OUT : It will light up when control output (Main Control Output) is on.
 - ※It will light up over 3.0% of operation in CYCLE/PHASE control.
 - AL1/AL2 : It will light up when alarm output AL1/AL2 are on.
- MODE Key : Used when entering into parameter setting group, returning to RUN mode, moving parameter and saving setting values.
- Adjustment : Used when entering into set value change mode, Digit moving and Digit Up/down.
- FUNCTION key : Press $\swarrow + \nearrow$ keys for 3 sec to operate function (RUN/STOP, alarm output cancel) set in inner parameter [dl -E].
 - ※Press $\swarrow + \nearrow$ keys once in set value operation to move digit.

Touch Switch Type Temperature Controller

Flow chart for setting group

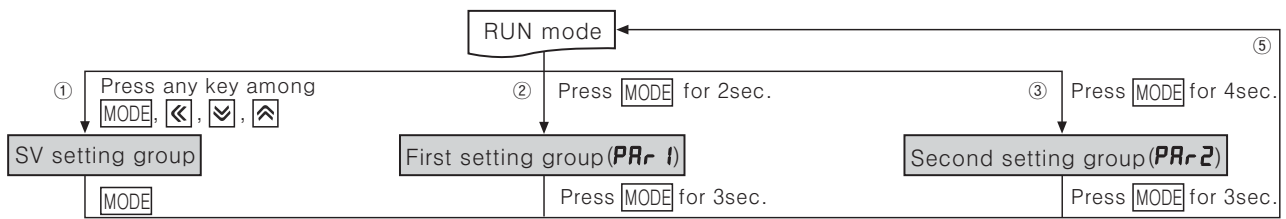

④	AL1	AL1 alarm temperature (Deviation/absolute value) setting
	AL2	AL2 alarm temperature (Deviation/absolute value) setting
	At	Enable/disable of auto-tuning setting
	P	Proportional band
	I	Integral time setting
	d	Derivative time setting
	rEST	Manual reset (Normal deviation correction) setting
	HYS	ON/OFF control hysteresis setting
	In-t	Input sensor
	Unit	Temperature unit
	In-b	Input correction
	∩ARF	Input digital filter
	L-Su	Low-limit value of ambient temperature
	H-Su	High-limit value of ambient temperature
	o-Ft	Control output operation (Cool/heat)
	C-nd	Control type
	oUt	Control output type
	SSr.∩	SSR output method
	t	Control cycle
	AL-1	AL1 alarm operation mode
	AL-2	AL2 alarm operation mode
	ALHYS	Alarm output hysteresis
	LbAt	Loop Break Alarm monitor time
	LbAS	LBA value
	LbAb	LBA width
	dl-∩	Function key operation
	Er.∩u	Control operation for input disconnection
	LoC	Lock setting

※Parameter marked in [] would not be displayed by another parameter setting.

- ① Press any key once in RUN mode, it advances to set value setting group.
- ② Press **MODE** key over 2sec in RUN mode, it advances to setting group 1.
- ③ Press **MODE** key over 4sec in RUN mode, it advances to setting group 2.
- ④ First parameter will be displayed on viewer when it advances to the setting group.
- ⑤ Press **MODE** key over 3sec in the setting group, it returns to RUN mode.
[※Exception : Press **MODE** key once in setting group of set value, it returns to RUN mode.]

※If no key touched for 30sec, it will return to RUN mode automatically and the set value of parameter will not be changed.

※Press **MODE** key again within a sec after return to RUN mode by press **MODE** key over 3sec, it advances to the first parameter of previous setting group.

※Parameter setup

Setting group2 → Setting group1 → Setting group of set value

- Set parameter as the above considering parameter relation of each setting group.
- Check parameter set value after change parameter of setting group2.
- Parameter marked in [] would not be displayed by another parameter setting.

※Indicator type displays colored parameter of setting group2.

※AL2 and AL-2 parameter display is available with only "Alarm output 1 + Alarm output 2" model.

Flow chart for SV setting group (※To change preset temperature 210℃ into 250℃.)

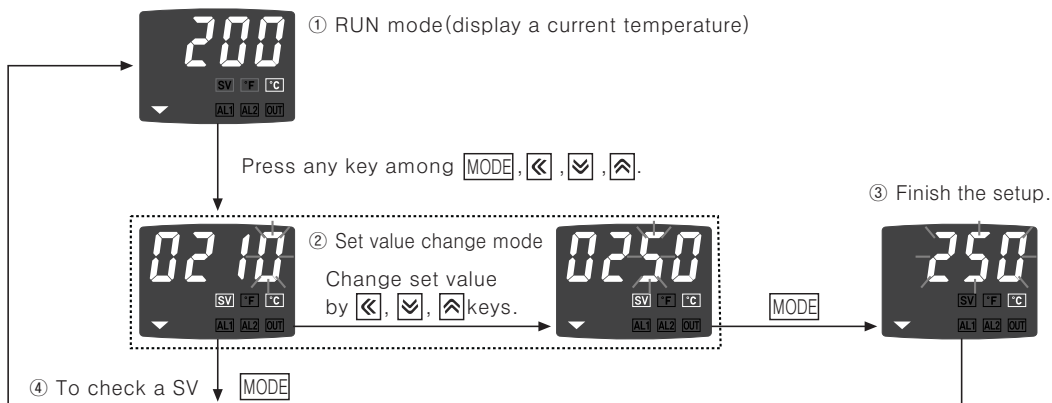

- (A) Counter
- (B) Timer
- (C) Temp. controller
- (D) Power controller
- (E) Panel meter
- (F) Tacho/Speed/Pulse meter
- (G) Display unit
- (H) Sensor controller
- (I) Switching power supply
- (J) Proximity sensor
- (K) Photo electric sensor
- (L) Pressure sensor
- (M) Rotary encoder
- (N) Stepping motor & Driver & Controller
- (O) Graphic panel
- (P) Production stoppage models & replacement

TC Series

Flow chart for first setting group

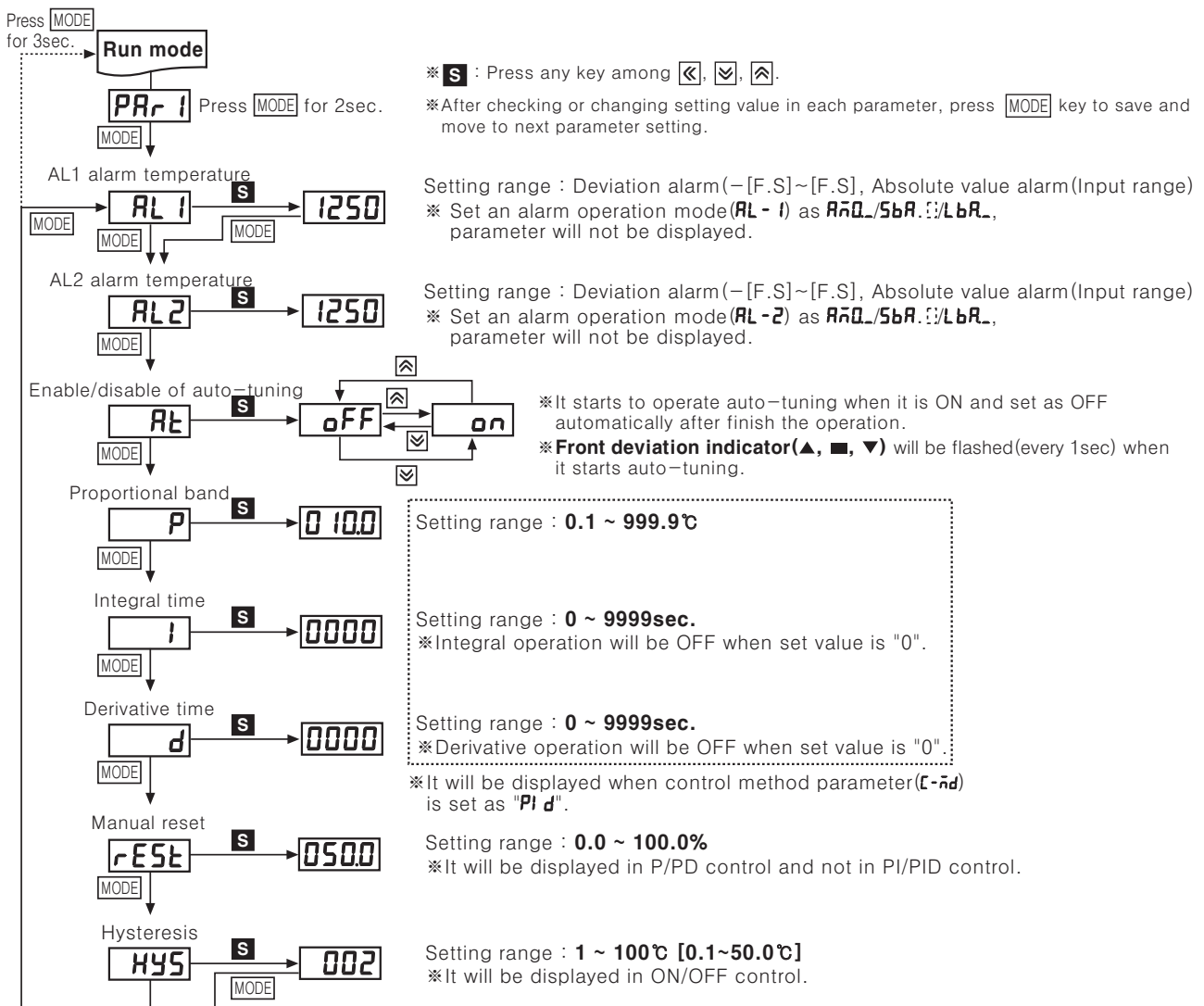

Flow chart for second setting group

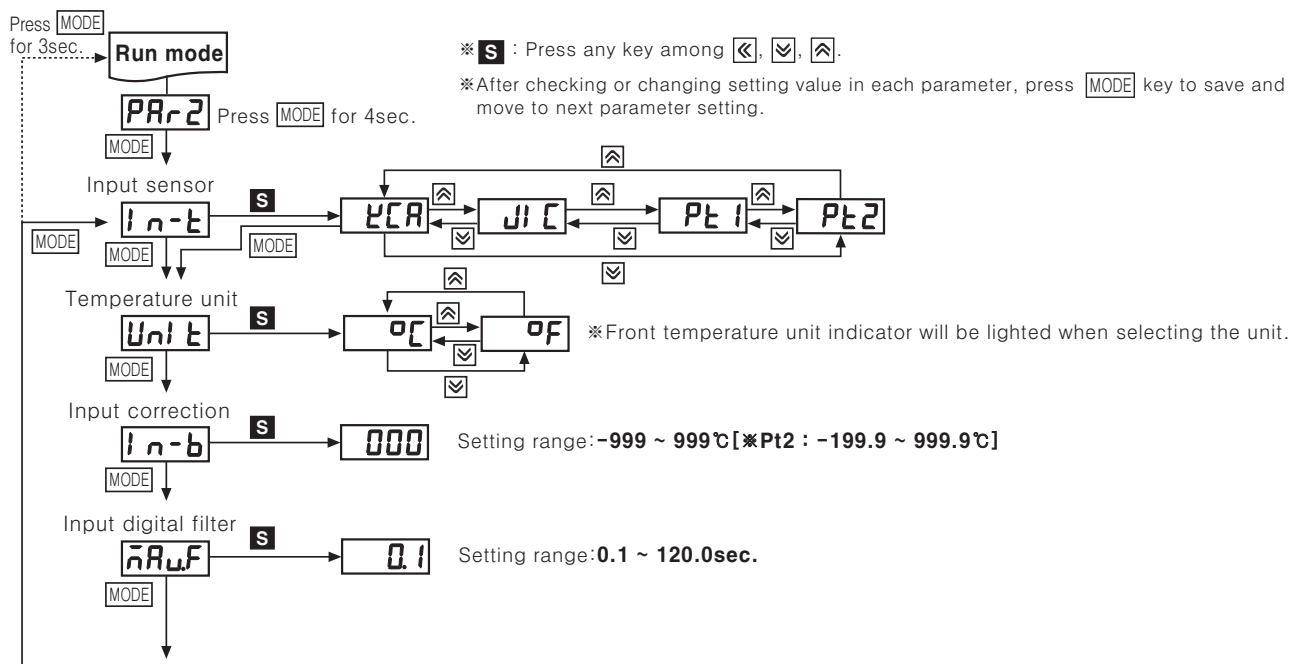

Touch Switch Type Temperature Controller

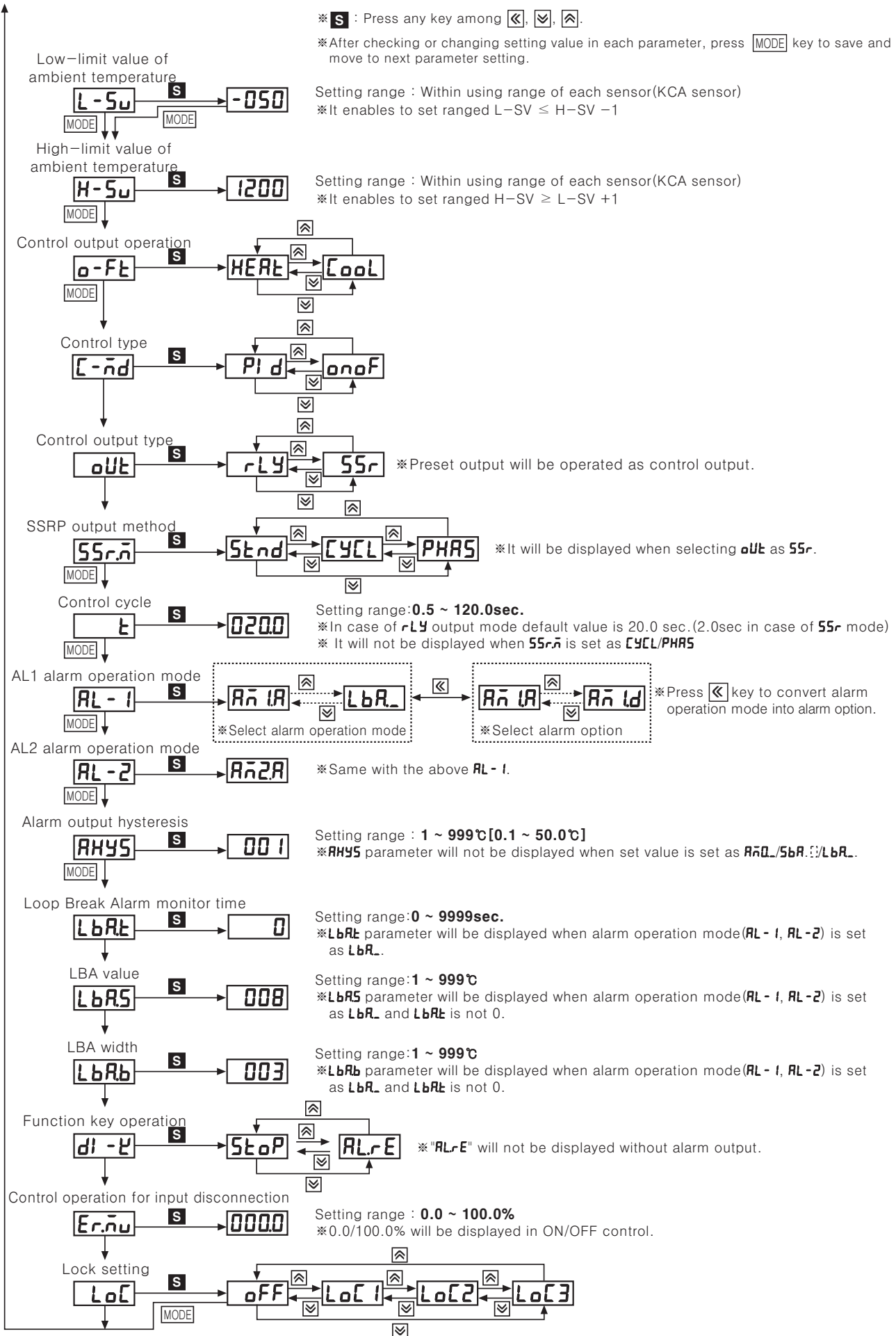

(A)	Counter
(B)	Timer
(C)	Temp. controller
(D)	Power controller
(E)	Panel meter
(F)	Tacho/Speed/Pulse meter
(G)	Display unit
(H)	Sensor controller
(I)	Switching power supply
(J)	Proximity sensor
(K)	Photo electric sensor
(L)	Pressure sensor
(M)	Rotary encoder
(N)	Stepping motor & Driver & Controller
(O)	Graphic panel
(P)	Production stoppage models & replacement

TC Series

Factory default

First setting group

Mode	Setting value	Mode	Setting value	Mode	Setting value	Mode	Setting value
AL1	1250	ALt	oFF	l	0	rESt	500
AL2	1250	P	100	d	0	HYS	2

Second setting group

Mode	Setting value	Mode	Setting value	Mode	Setting value	Mode	Setting value	Mode	Setting value
l n-t	℄CA	L-Su	-50	oUt	rLY	AL-2	Añ2A	LbAb	3
Unl t	°C	H-Su	1200	SSrñ	Stnd	AHYS	1	dl -℄	StoP
l n-b	0	o-Ft	HEARt	t	200	LbARt	0	Erñu	00
ñARwF	0.1	C-ñd	Pl d	AL-1	Añ1A	LbAS	8	LoC	oFF

Input sensor and range [l n-t]

Select proper input sensor set type by user application.

Input sensor		Display	Input range °C	Input range °F
ThermoCouple	K(CA)	℄CA	-50 ~ 1200°C	-58 ~ 2192°F
	J(IC)	Jl C	-30 ~ 500°C	-22 ~ 932°F
RTD	DIN rated	Pt 1	-100 ~ 400°C	-148 ~ 752°F
		Pt 2	-100.0 ~ 400.0°C	-148.0 ~ 752.0°F

Alarm output operation mode [AL - 1 / AL - 2]

Mode	Alarm output operation	Description(The initial value of AL1/AL2 is KCA.)
Añ0_	_____	■No alarm output.
Añ10		■Deviation high-limit alarm If deviation between PV and SV is occurring higher than set value of deviation temperature, the output will be ON. The deviation temperature is set in AL1/AL2. (Default of AL1, AL2 : 1250)
Añ20		■Deviation low-limit alarm If deviation between PV and SV is occurring lower than set value of deviation temperature, the output will be ON. The deviation temperature is set in AL1/AL2. (Default of AL1, AL2 : 1250)
Añ30		■Deviation high/low-limit alarm If deviation between PV and SV is occurring higher or lower than set value of deviation temperature, the output will be ON. The deviation temperature is set in AL1/AL2. ※It is ON if AL value < 0 (Default of AL1, AL2: 1250)
Añ40		■Deviation high/low-limit reverse alarm If deviation between PV and SV is occurring higher than set value of deviation temperature, the output will be OFF. The deviation temperature is set in AL1/AL2. ※It is OFF if AL value < 0 (Default of AL1, AL2: 0)
Añ50		■Absolute value high-limit alarm If PV is equal to or higher than the absolute value of alarm temperature, the output will be ON. The absolute temperature is set in AL1/AL2. (Default of AL1, AL2 : 1200)
Añ60		■Absolute value low-limit alarm If PV is equal to or lower than the absolute value of alarm temperature, the output will be ON. The absolute temperature is set in AL1/AL2. (Default of AL1, AL2 : -50)
SbA_	It will be ON when it detects sensor disconnection.	■Sensor Break Alarm
LbA_	It will be ON when it detects loop break.	■Loop Break Alarm

※Alarm output hysteresis [AHYS]

- Above alarm output operation mode, "H" is alarm output hysteresis which displays alarm output's on/off interval. User settable.
- When setting alarm operation (AL - 1/AL - 2) mode as "Añ0_", "SbA_", "LbA_", parameter will not be displayed.

Touch Switch Type Temperature Controller

Optional alarm output selection

Display	Alarm mode	Description
	General alarm	When PV reaches alarm temp.(deviation), Aux output will be ON.
	Latch	When PV reaches alarm temp.(deviation), Aux output will be ON and retained.
	Standby	When PV reaches alarm temp.(deviation) for the second time, Aux output will be ON.(No output will be on for initial operation.)
	Latch & Standby	Latch and Standby mode applied together.

Function

SV / PV Deviation Display Function

A function to display SV / PV deviation on front lamp

- When PV is higher than SV over $+2^{\circ}\text{C}$ ($+2.0^{\circ}\text{C}$), ▲ (RED) lamp is ON. ($\text{PV} > \text{SV} + 2.0^{\circ}\text{C}$)
- When PV / SV deviation is $\pm 2^{\circ}\text{C}$ ($\pm 2.0^{\circ}\text{C}$), ■ (GREEN) lamp is ON. ($\text{SV} + 2.0^{\circ}\text{C} \geq \text{PV} \geq \text{SV} - 2.0^{\circ}\text{C}$)
- When PV is lower than SV over -2°C (-2.0°C), ▼ (RED) lamp is ON. ($\text{PV} < \text{SV} - 2.0^{\circ}\text{C}$)

Auto Tuning Function [AT]

PID Auto Tuning is a function to figure out PID time constants for optimal control by measuring thermal characteristics or thermal response time of control objects in order to realize high speed response time and high stability control.

- In order to perform Auto tuning function
 - SET [AT] parameter to "ON"
 - Front deviation display lamp (▲, ■, ▼) will be flickering (cycle:1 sec) during Auto tuning.
 - After completing Auto tuning, deviation display lamp (▲, ■, ▼) returns to normal operation and [AT] parameter becomes OFF.

- In case of "oPEr" error, Auto tuning is not applicable. When "oPEr" error occurs, stop the function.
- In case of "HHHH", "LLLL" error, Auto tuning keeps operating and finishes normally as long as certain conditions are met.

Control Mode Selection [C-nd]

It is selectable PID, ON/OFF control.

- PID, ON / OFF mode selectable
- In case of ON / OFF mode, Hysteresis parameter (HYS) is displayed.
- In case of PID mode, Proportional band(P), Reset time(t) and Rate time(t) parameters are displayed.

HYSTERESIS [HYS]

Set control output ON / OFF interval in ON / OFF control mode.

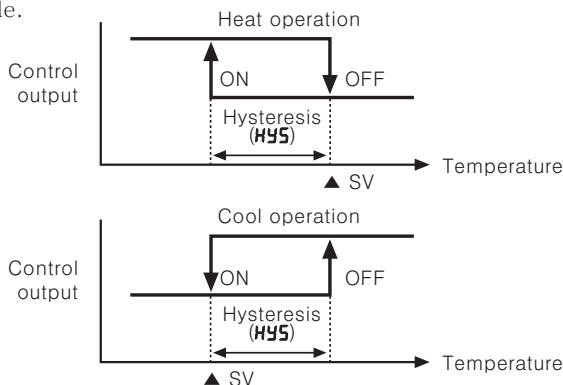

- If Hysteresis is too narrow, hunting (Oscillation, Chattering) could occur due to external noise.
- In case of ON / OFF control mode, even if PV reaches stable status, there still occurs hunting. It could be due to Hysteresis SV, load's response characteristics or sensor's location. In order to reduce hunting to a minimum, it is required to take into following factors consideration when designing temp. controlling; proper Hysteresis, heater's capacity, thermal characteristics, sensor's response and location.

Manual Reset Function [rESt]

When selecting P / PD control mode, there exists certain temperature difference even after PV reaches stable status since heater's rising and falling time is inconsistent due to thermal characteristics of control objects, such as heat capacity, heater capacity. This temperature difference is called OFFSET and manual reset function is to set / correct OFFSET.

- How to set
 - When PV and SV are equal, reset value is 50.0%.
 - When $\text{PV} \leq \text{SV}$, reset value $> 50.0\%$
 - When $\text{PV} \geq \text{SV}$, reset value $< 50.0\%$
- Reset (rESt) setting depending on control results

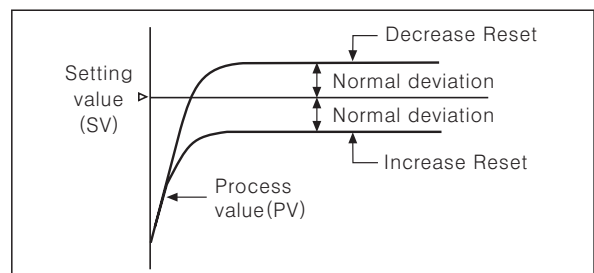

※Manual reset function is applicable only to P / PID control mode.

Temperature Unit Selection Function [Uo/ t]

- A function to select display temperature unit
- Front unit display lamp will be ON when converting temperature unit

(A) Counter

(B) Timer

(C) Temp. controller

(D) Power controller

(E) Panel meter

(F) Tacho/ Speed/ Pulse meter

(G) Display unit

(H) Sensor controller

(I) Switching power supply

(J) Proximity sensor

(K) Photo electric sensor

(L) Pressure sensor

(M) Rotary encoder

(N) Stepping motor & Driver & Controller

(O) Graphic panel

(P) Production stoppage models & replacement

TC Series

◎Cool / Heat Function[α -Ft]

There are two temperature controlling applications, one is heating and the other is cooling.

- Heating: When PV is lower than SV, control output will be ON to supply power to the load (heater) and vice versa.
- Cooling: When PV is higher than SV, control output will be ON to supply power to the load (cooler) and vice versa.
- In case of ON / OFF control, or P control mode, Control output for Cooling / Heating is opposite to each other.
- In case of PID mode, PID time constants for Cooling / Heating are different from each other since PID time constants are determined depending on each control object.

- Cool-function(Cool) and heat-function(HEAT) must be set correctly according to the application, if set as opposite function, it may cause a fire.
(If set cool-function(Cool) at heater, even if temperature is getting high, it will be maintained ON and it may cause a fire.)
- Avoid changing heat-function to cool-function or cool-function to heat-function on the unit is operating.
- It is impossible to operate both function at once in this unit. Therefore, only one function should be selected only.

◎Sensor Break Alarm(SBA)[5bR]

A function to make alarm output ON when sensor line is cut or open. It is possible to check sensor break using relay contacts for alarm output or buzzers.

- Set alarm mode parameter (AL-1, AL-2) "5bR"
- 5bR_A / 5bR_B selectable
- Reset alarm output or power off the unit to make alarm output OFF.

◎Loop Break Alarm(LBA)[LbR]

When control deviation (SV-PV) is smaller than LBA detection width during LBA monitoring time, it is considered control loop break and LBA output will be ON.

- Auto tuning is not applicable while LBA mode.
- When alarm reset mode is applied, the starting point of LBA monitoring will be initialized.

※ When selecting alarm output mode (AL-1, AL-2), or LBA mode (LbR), related parameters (LbR_A, LbR_S, LbR_B) are displayed.

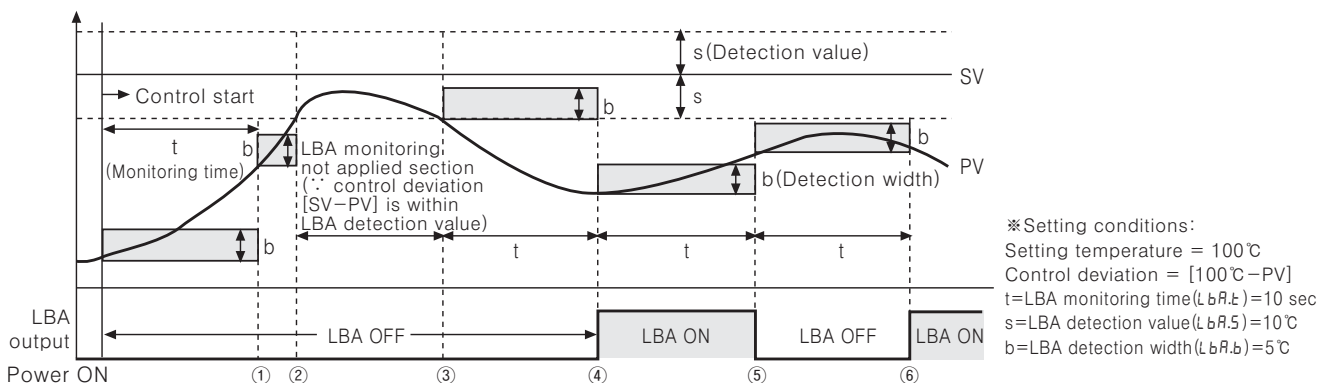

◎FUNCTION key selection[dl -P]

Press front keys $\blacktriangledown + \blacktriangle$ at the same time for 3 sec to have previously set operation in parameter performed. You can choose between control output stop and alarm output off.

It enables to stop control output without power off in RUN mode. [StopP]

- It is set as "StopP" if it does not have alarm output.
- Sub outputs will be operated as they set and it might keep "StopP" status after power off, press front keys $\blacktriangledown + \blacktriangle$ to off the "StopP".
- Alarm off [AL-E]
 - User can off the alarm output during alarm (AL-1, AL-2) output is ON in latch & standby sequence function. (But, if PV is in alarm output range, it is disabled.)

◎Control Output RUN / STOP

It is allowed for users to select RUN / STOP mode in RUN mode.

- When it is required to stop control output temporarily (e.g., during maintenance work), use "STOP" command to stop control output. (Auxiliary output is normally provided as setting values.)
- When power is off in "STOP" mode, "STOP" mode will be kept after Power is supplied again. (In order to return to normal control operation, make "STOP" mode OFF using front keys.)

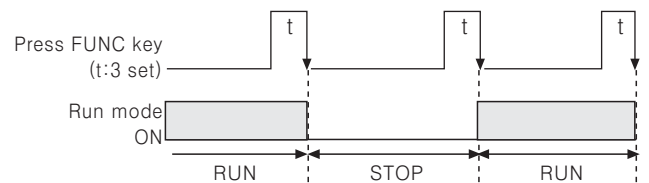

Touch Switch Type Temperature Controller

◎Alarm Reset

A function to reset or initialize alarm output by force while Latch / Latch & Standby mode

- Applicable only to Latch and Latch / Standby mode
- Available only if PV is within alarm output setting range

◎Control Output Selection[$\alpha U E$]

A function to select control output type; Relay output ($r L Y$), SSRP voltage output ($55 r$).

※In case of selecting SSRP voltage output, SSRP output type ($55 r \bar{n}$) selection parameter is displayed.

◎Input Correction[$I n - b$]

Input correction is to correct deviation occurred from temperature sensor such as thermocouples, RTD etc.

- If you check the deviation of every temperature sensor precisely, it can measure temperature accurately.
- Use this mode after measuring deviation occurred from temperature sensor exactly.

Because if measured deviation value is not corrected, displayed temperature may be too high or too low.

- When you set the Input revise value, you may need to record it, because it will be useful when performing maintenance.

◎Input Digital Filter[$\bar{n} A \mu F$]

A function to filter input signals for more stable PV display in order to provide stable control output. If noise occurs on input signals or PV value keeps changing, it gets difficult to perform high accuracy control since PV has a direct effect on output level.

◎Upper/Lower Limit of set temperature [$L - S u / H - S u$]

- It sets upper/lower Limit range of using temperature within temperature range for each sensor, user can set/change set temperature (SV) within upper-limit [$H - S u$] ~ lower-limit [$L - S u$]. (※ $L - S u > H - S u$ cannot be set.)

- When changing input specification ($I n - b$), upper-limit ($H - S u$) and lower-limit ($L - S u$) of using temperature will be initialized as max./min. value of sensor temperature range automatically.

◎Control output(MV for Error) for sensor input disconnection error($\alpha P E n$) [$E r \bar{n} u$]

- It sets control output when sensor input disconnection error is occurred enabling to set as ON/OFF and operation set by user.
- It executes control output by set operations regardless of ON/OFF and PID control operations.

◎Lock setting[$L o C$]

- It locks set value and parameter change of the group.
- It enables to check parameter set value of locked setting group.

Display	Description
$\alpha F F$	Lock off
$L o C 1$	Lock setting group 2
$L o C 2$	Lock setting group 1, 2
$L o C 3$	Lock setting group 1, 2, SV setting group

※ $\alpha F F$, $L o C 1$ are available only for indicator (TC4□-N□N).

◎Error

- Error mark will flash (every 1sec) in PV viewer when error is occurred during the control operation.

Display	Description
$\alpha P E n$	If input sensor is disconnected or sensor is not connected.
$H H H H$	If measured sensor input is higher than temperature range.
$L L L L$	If measured sensor input is lower than temperature range.

- It will operate normally, if input sensor is connected or returned to normal range under error $\alpha P E n / H H H H / L L L L$ status.

◎Output connections

- Application of relay output type

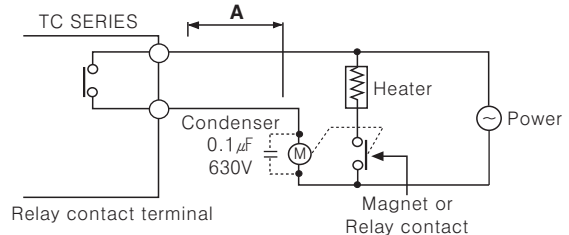

Keep power relay as far away as possible from temperature controller. If wires length of **A** is short, electromotive force occurred from a coil of magnet switch & power relay may flow in power line of the unit, it may cause malfunction. If wires length of **A** is short, please connect a mylar condenser 104 (630V) across coil of the power relay "M" to protect electromotive force.

- Application of SSRP output type

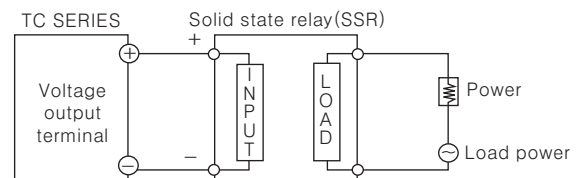

※SSR should be selected by the capacity of load, otherwise, it may short-circuit and result in a fire. Indirect heated should be used with SSR for efficient working.

※Please use a cooling plate or it may cause the capability deterioration, breakdown of SSR for a long usage.

※Refer to C-11 page for phase / cycle control connections.

(A) Counter

(B) Timer

(C) Temp. controller

(D) Power controller

(E) Panel meter

(F) Tacho/Speed/Pulse meter

(G) Display unit

(H) Sensor controller

(I) Switching power supply

(J) Proximity sensor

(K) Photo electric sensor

(L) Pressure sensor

(M) Rotary encoder

(N) Stepping motor & Driver & Controller

(O) Graphic panel

(P) Production stoppage models & replacement

■ Proper usage

◎ Simple "error" diagnosis

- In case, the load (Heater etc) is not operated, please check operation of the out lamp located in front panel of the unit. If lamp does not operate, please check the parameter of all programmed mode. If lamp is operating, please check the output (Relay, Driving voltage of SSR) after separating output line from the unit.
- When it displays "OPEN" during operation.
This is a warning that external sensor is cut off. Please turn off power and check the state of sensor. If sensor is not cut off, disconnect sensor line from terminal block and +, - together. When you turn on power it can check room temperature. If this unit cannot indicate room temperature, this unit itself is faulty. Please remove this unit from equipment and service or replace.
(When the input mode is thermocouple, it is available to indicate room temperature.)
- In case of indicating "Error" in display
This Error message is indicated in case of damaging inner chip program data by outer strong noise. In this case, please send the unit to our after service center after removing the unit from system. Noise protection is designed in this unit, but it does not stand up strong noise continuously. If bigger noise than specified (Max. 2kV) flows in the unit, it can be damaged.

◎ Caution for using

- Please use the terminal (M3.5, Max. 7.2mm) when connecting the AC power source.
- "⚠" mark indicated on the diagram of this unit means caution—refer to accompanying documents.
- In case of cleaning the unit, please keep as following Cautions;
 - ① Clean dust with a dry tissue.
 - ② Be sure to use alcohol to clean the unit, do not use acid, chromic acid, solvent, etc.
 - ③ Be sure to clean the unit after turning off the power and then turn on the power after passing 30minute after cleaning.
- If this unit is used in a manner not to be specified by the manufacture, it can be injury to a person or damage to property.
- Be sure that metal dust and wire-dregs do not flow in the unit, because of malfunction damage of the unit or the cause of a fire.
- Service life for the relay of the unit is indicated in this manual, life cycle is different according to the load capacity and switching times, therefore please use the unit after checking the load capacity and switching times.
- Connect wires correctly after checking polarity of terminals.
- Do not use this unit as following place.
 - ① A place where dust, corrosive gas, oil, moisture are occurred.
 - ② A place where there are high humidity or freezing place.
 - ③ A place where sunshine, radiant heat is occurred.
 - ④ A place where vibration, shock is occurred.
- If the equipment is used in a manner not specified by the manufacture the protection provided by the equipment may be impaired.
- Please install power switch or circuit-breaker in order to cut power supply off.
- A switch or circuit-breaker meeting the relevant requirements of IEC947-1 and IEC947-3 shall be included in equipment when the temperature controller.
- The switch or circuit-breaker should be installed near by users.
- Installation environment
 - ① It shall be used indoor
 - ② Altitude Max. 2000m
 - ③ Pollution Degree 2
 - ④ Installation Category II.
- This SSRP of this controller are insulate from internal power.
- Do not connect power line to sensor connecting part. The inner circuit may be damaged.